

Oil Lubricated Vacuum Pumps: GP100K & GPM100K

Pump type GP-GP/M 100K

Pump type GP-GP/M 100 ATEX



- GP series Oil lubricated vacuum pumps is highly reliable and proven model for industrial applications.
- These GP series vacuum pumps are designed for operational reliability and efficiency.
- GP rotary vane vacuum pumps are energy-efficient pumps used in various applications. Pump is available also in FOOD version for food industry
Pump is available also complying with ATEX Directive 2014/34/EU

Each pump is complete of:

- oil remover cartridge & oil recovery system (with oil return pipe) to avoid any oil mist at the pump exhaust.
- Non return valve installed within the pump to avoid any flux back into the process.
- forced ventilation Air cooling system keeps the pump in good working temperature.
- Direct transmission with direct coupling and guard.
- Composite vanes (glass epoxy sheet), asbestos free, specified to grant high sliding and wear resistant.
- Two numbers of oil sight Pyrex glass ports.

Pump Materials:

Pump body and cover: Cast Iron

Rotor : Carbon steel

Gasket : Viton

Oil chamber : Aluminium

Exhaust Recycler : Aluminium

Oil chamber and exhaust recycler will be housed in only one piece.

UNIQUE VACUUM SOLUTIONS

Pumping speed curve:

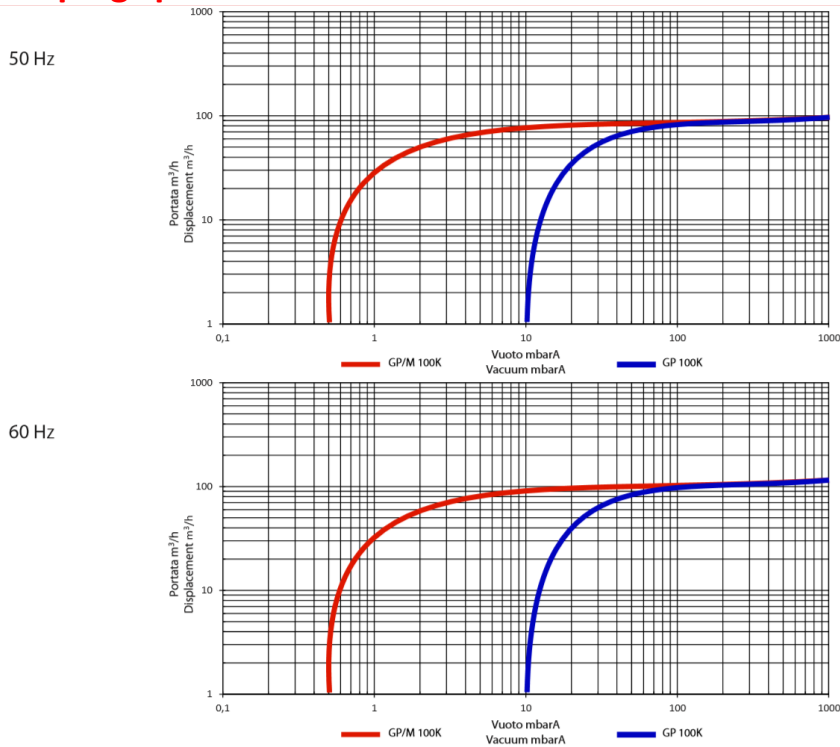

Dimensions:

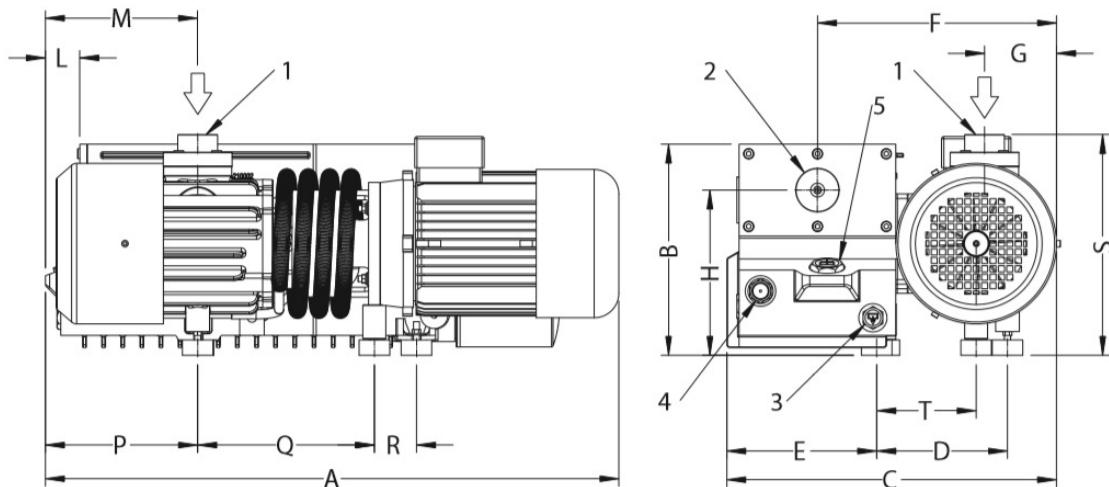

1-Suction, 2-Discharge, 3-Oil discharge plug, 4-Oil sight glass, 5-Oil fill up plug

	Dimensioni (mm) Dimension (mm)														
GP-GP/M	A	B	C	D	E	F	G	H	L	M	P	Q	R	S	T
100K	749	276	431	171	196	312	94	216	45	199	199	231	55	288	130

UNIQUE VACUUM SOLUTIONS

#57, 8th cross, 1st B cross, Doddanna Industrial Estate, Vishwaneedam Post, near peenya 2nd stage, BANGALORE - 560091. INDIA

91-9886726920, 080-28367059
 nagendrautpath@uniquevacuum.co.in,
 support@uniquevacuum.co.in
 www.uniquevacuum.co.in



Vacuum Products & Helium Leak Test

UNIQUE VACUUM SOLUTIONS

SPECIFICATION:		PUMP MODEL / FREQUENCY			
		GP100K 50Hz	GP100K 60Hz	GPM100K 50Hz	GPM100K 60Hz
Displacement	m ³ /hr	100	120	100	120
Ultimate vacuum	mbar	10	10	0.5	0.5
Noise level without gas ballast	db (A)	70	74	70	74
Ultimate vacuum with gas ballast	mbar	14	14	1.5	1.5
Max water vapour quantity acceptable with gas ballast	Kg/h	1.7	2	1.7	2
Standard voltage	V	230/400	460	230/400	460
Motor power	kW	2.2	3	2.2	3
RPM	g/1'	1450	1750	1450	1750
Weight with oil	Kg	98	98	98	98
Oil quantity	L	5	5	5	5
Inlet connection		1 ¼" GAS	1 ¼" GAS	1 ¼" GAS	1 ¼" GAS
Outlet connection		2" GAS	2" GAS	2" GAS	2" GAS

UNIQUE VACUUM SOLUTIONS

#57, 8th cross, 1st B cross, Doddanna Industrial Estate, Vishwaneedam Post, near peenya 2nd stage, BANGALORE - 560091. INDIA

91-9886726920, 080-28367059
nagendrautpath@uniquevacuum.co.in,
support@uniquevacuum.co.in
www.uniquevacuum.co.in